

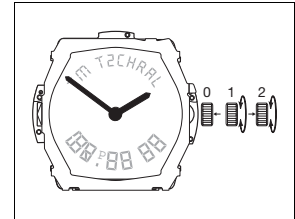

11^{'''} x 11 1/2^{'''} ETA 988.432

CT 988432 ESI 492530 02 13.03.2012

11^{'''} x 11 1/2^{'''} Ø 24,80 x 25,50 mm



Movement height	Altura sobre máquina	Altezza sopra movimento	3,25 mm
Height on battery	Altura sobre pila	Altezza sopra pila	No 370: 3,80 mm No 399: 4,30 mm
Number of jewels	Número de piedras	Numero di pietre	7
Frequency	Frecuencia	Frequenza	32'768 Hz

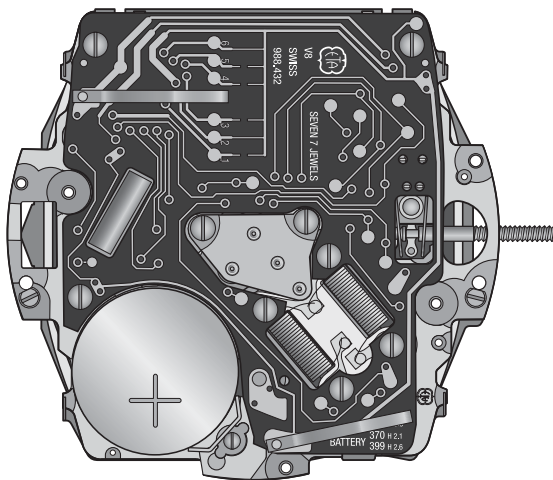

The repair and reconditioning work must only be performed by properly trained personnel.
Las tareas de reparación y revisión sólo deben ser llevadas a cabo por personal debidamente formado.
I lavori di riparazione e di revisione devono essere eseguiti esclusivamente da personale adeguatamente formato.



General information



Before starting work, please study this "Technical communication" carefully.



Eye protection is obligatory for all operations / work on the movement!



ETA SA disclaims any liability in case of damage arising from failure to observe this "Technical communication".

Environmental protection requirements



The legal provisions relating to waste handling and disposal must be observed in all operations / work on the movement!

In particular, lubricating and cleaning products harmful to the environment must be disposed of in accordance with the rules!



Substances prone to cause water pollution must be stored, transported, collected and disposed of in appropriate vessels.

Under no circumstances must they pollute the soil or be poured into sewage systems!

Explanation of symbols



Caution! Risk of material damage!

Below are some obligatory instructions for preventing any material damage!

Información general



Esta "Comunicación técnica" deberá estudiarse muy bien **antes** de comenzar los trabajos.



Es obligatorio utilizar protección ocular para todos los trabajos en y con el reloj.



ETA SA no se hace responsable de los daños provocados como consecuencia de la inobservancia de esta "Comunicación técnica".

Normas de protección medioambiental



Deberá cumplirse la normativa legal relativa al reciclaje y la eliminación correctos de los residuos en todos los trabajos en y con el reloj.

En especial, deberán eliminarse correctamente los productos lubricantes y de limpieza peligrosos para el medio ambiente.



Las sustancias contaminantes del agua deben recogerse, almacenarse, transportarse y eliminarse en recipientes adecuados.

En ningún caso se permitirá que contaminen el suelo o que lleguen a la canalización.

Significado de los símbolos



Atención Peligro de daños materiales

Instrucciones que deberán respetarse necesariamente para evitar daños materiales.

Informazioni generali



Questa "Comunicazione Tecnica" deve essere studiata attentamente **prima** dell'inizio dei lavori.



Per tutti i lavori su e con il movimento dell'orologio è obbligatorio proteggere gli occhi!



ETA SA declina qualunque responsabilità per eventuali danni causati dalla mancata osservanza della presente "Comunicazione tecnica".

Disposizioni relative alla protezione ambientale



Per tutti i lavori su e con il movimento dell'orologio si dovranno rispettare le disposizioni di legge relative al corretto riciclaggio e smaltimento dei rifiuti!

In particolare si dovrà provvedere al corretto smaltimento di lubrificanti e detergenti nocivi per l'ambiente!



Le sostanze inquinanti per l'acqua devono essere conservate, trasportate, raccolte e smaltite in contenitori adatti.

Queste non devono inquinare il terreno o arrivare nelle canalizzazioni!

Spiegazione dei simboli



Attenzione! Pericolo di danni materiali!

Seguono importanti indicazioni che devono essere tassativamente rispettate per evitare danni materiali!

List of components - Lista de piezas - Lista fornitori

Pos	No	No CS	Article number Número de artículo Numero articolo		List of components	Lista de piezas	Lista fornitori
-	100	10.020.07	Var		Main plate, jewelled	Platina, empedrada	Piastra, con pietre
-	110	10.048.06	Var		Train wheel bridge, assembled	Puente de rodaje, montado	Ponte del ruotismo, montato
-	201	30.015.00	Var		Centre wheel	Rueda de centro	Ruota di centro
-	203	30.012.00	-		Intermediate wheel	Rueda intermedia	Ruota intermedia
-	250/1	31.046.06	-		Hour wheel, assembled	Rueda de horas, montada	Ruota delle ore, montato
-	260	31.041.00	-		Minute wheel	Rueda de minutería	Ruota della minuteria
-	405	51.020.00	Var		Handsetting stem	Tija de puesta en hora	Albero di messa all'ora
-	407	31.121.00	-		Sliding pinion	Piñón corredizo	Pignone scorrevole
-	443/1	51.080.06	-		Setting lever, assembled	Tirete, ajustado	Tiretto, montato
-	445	51.090.00	-		Setting lever jumper	Muelle flexible de tirete	Scatto del tiretto
-	479	61.090.00	-		Banking spring for setting lever	Muelle apoyo de tirete	Molla appoggio del tiretto
-	499	61.241.00	-		Friction spring	Muelle-fricción	Molla frizione
-	4000	10.513.00	Var		Electronic module	Módulo electrónico	Modulo elettronico
-	4021	20.582.00	-		Stator	Estator	Statore
-	4033	53.100.00	Var		Display module clamp	Brida de sujeción del módulo de indicación	Brida di fissaggio del modulo di affissione
-	4046	20.651.00	-		Battery insulator	Aislador de pila	Isolatore della pila
-	4060	20.590.00	-		Coil	Bobina	Bobina
-	4211	20.580.00	-		Rotor	Rotor	Rotore
-	4405	20.765.00	-		Contact strip	Brida de contacto	Brida di contatto
-	4407	20.764.00	-		Earth connector	Brida de masa	Flangia della massa
-	4411	20.652.00	-		Battery bridge insulator	Aislador de brida de pila	Isolatore di brida della pila
-	4452	14.602.00	-		Piezo	Piezo	Piezo
-	4820	56.520.00	-		Connector	Conector	Connettore
-	4880	56.590.00	-		Display module positioning wedge	Calza de posición del módulo de indicación	Bietta di posizione del modulo di affissione
-	4929	20.570.00	-		Battery H. 2.10 mm	Pila H. 2,10 mm	Pila H. 2,10 mm
-	4929/1	20.570.00	-		Battery H. 2.60 mm	Pila H. 2,60 mm	Pila H. 2,60 mm
-	9447	10.014.00	Var		Display module LCD	Módulo de señalamiento LCD	Modulo di affissione LCD
-	5110	10.048.01	-	2x	Screw for train wheel bridge	Tornillo del puente de rodaje	Vite del ponte del ruotismo
1)	5445	51.090.01	-	1x	Screw for setting lever jumper	Tornillo de muelle flexible de tirete	Vite dello scatto del tiretto
-	5445 ¹	51.090.02	-	1x	Maintaining screw for setting lever jumper	Tornillo de sujeción de muelle flexible de tirete	Vite di sostegno dello scatto del tiretto
1)	5479	61.090.01	-	1x	Screw for banking spring for setting lever	Tornillo de muelle apoyo de tirete	Vite della molla d'appoggio del tiretto
2)	54000	10.513.01	-	3x	Screw for electronic module	Tornillo del módulo electrónico	Vite del modulo elettronico
2)	54060	20.590.01	-	4x	Screw for coil	Tornillo de la bobina	Vite della bobina
-	54405	20.765.01	-	1x	Screw for contact strip	Tornillo de la brida de contacto	Vite della brida di contatto
-	54407	20.764.01	-	1x	Screw for earth connector	Tornillo de brida de masa	Vite della flangia della massa
					Identical screws Tornillos idénticos Viti identiche	1) 5445 5479	2) 54000 54060
			Var		Variant	Variante	Variante

**Interchangeability and variants
can be found on the
ETA ONLINE SHOP (EOS):**

www.eta.ch

- Support Center
- Support Center Portal

**La intercambiabilidad y las
variantes se encuentran en
ETA ONLINE SHOP (EOS):**

www.eta.ch











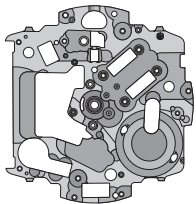











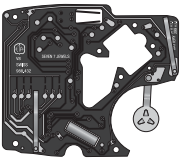

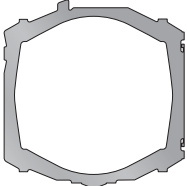
- Support Center
- Support Center Portal

**L'intercambiabilità e le varianti si
trovano sul
ETA ONLINE SHOP (EOS):**

www.eta.ch

- Support Center
- Support Center Portal

Materials- Fornituras - Forniture

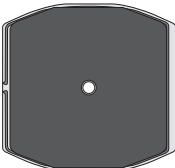
						5110
100 Var	110 Var	201 Var	203	250/1 Var	260	5445 5479
						5445 ¹
405 Var	407	443/1	445	479	499	54000 54060
						54405
4000 Var	4021	4033 Var	4046	4060		54407
						
4211	4405	4407	4411	4820	4880	
						
4929 H 2,10 mm	4929/1 H 2,60 mm	9447 Var				

Order of assembly - Orden del montaje - Ordine dell'assemblaggio
Basic movement - Máquina de base - Movimento di base

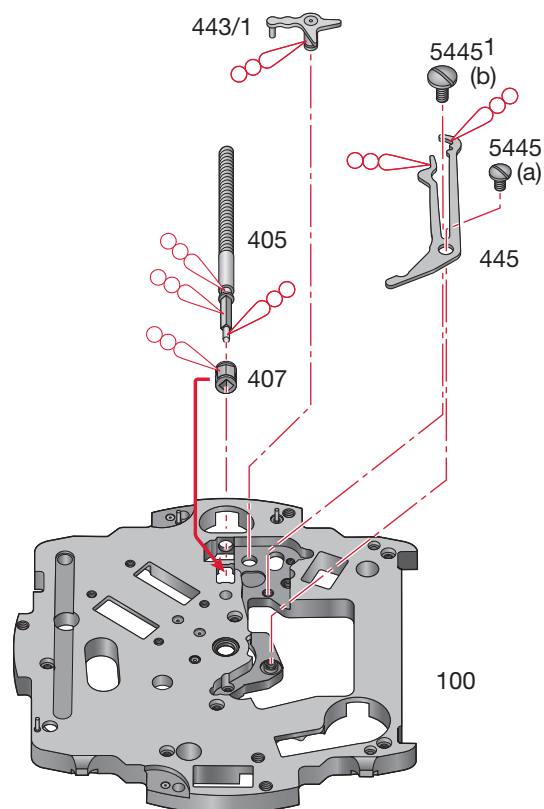

Assembling of the basic movement

(Parts listed in order of assembly)

Montaje de la máquina de base

(Lista de fornitureas por orden de ensamblado)

Montaggio del movimento di base

(Elenco delle forniture in ordine di montaggio)

100	443/1	5445 ¹ (1x)
407	445	
405	5445 (1x)	

Lubrication - Lubricación - Lubrificazione

Thick oil or grease

Aceite espeso o grasa

Olio denso o grasso

Moebius D5**M_L Minimum torque for loosening****M_L Par mínimo para desatornillar****M_L Coppia minima per svitare**

- (a) 0,7 Ncm
- (b) 0,6 Ncm

Order of assembly - Orden del montaje - Ordine dell'assemblaggio:
 Assembling of the electronic part - Módulo motor - Modulo motore

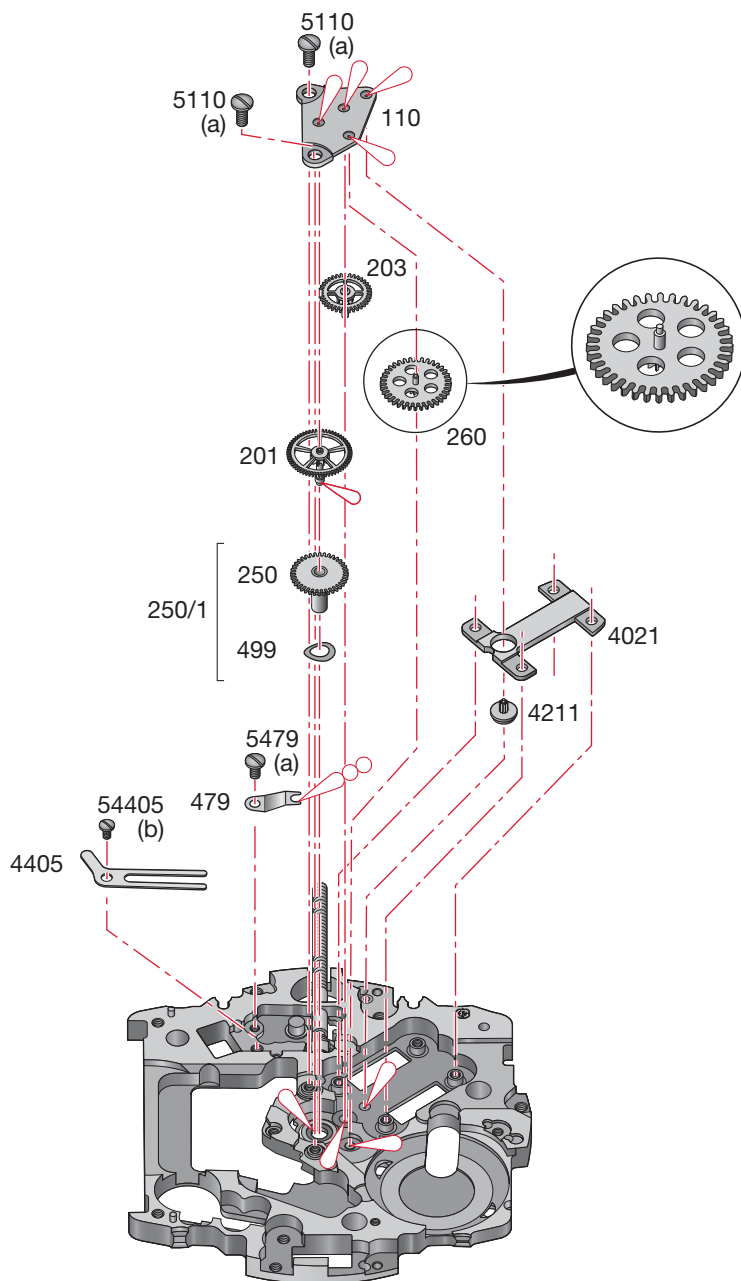

Assembling of the electronic part

(Parts listed in order of assembly)

Montaje del módulo motor

(Lista de fornitureas por orden de ensamblado)

Montaggio del modulo motore

(Elenco delle forniture in ordine di montaggio)

479	4021	201
5479 (1x)	4211	203
4405	250	110
54405 (1x)	260	5110 (2x)

Lubrication - Lubricación - Lubrificazione

 Fine oil **Moebius 9014**
 Aceite fino or / ó / o
 Olio fluido **Moebius 9034**

 Thick oil or grease **Moebius D5**
 Aceite espeso o grasa
 Olio denso o grasso

M_L Minimum torque for loosening**M_L Par mínimo para desatornillar****M_L Coppia minima per svitare**

- (a) 0,7 Ncm
 (b) 0,6 Ncm

Order of assembly - Orden del montaje - Ordine dell'assemblaggio
Electronic module - Módulo electrónico - Modulo elettronico

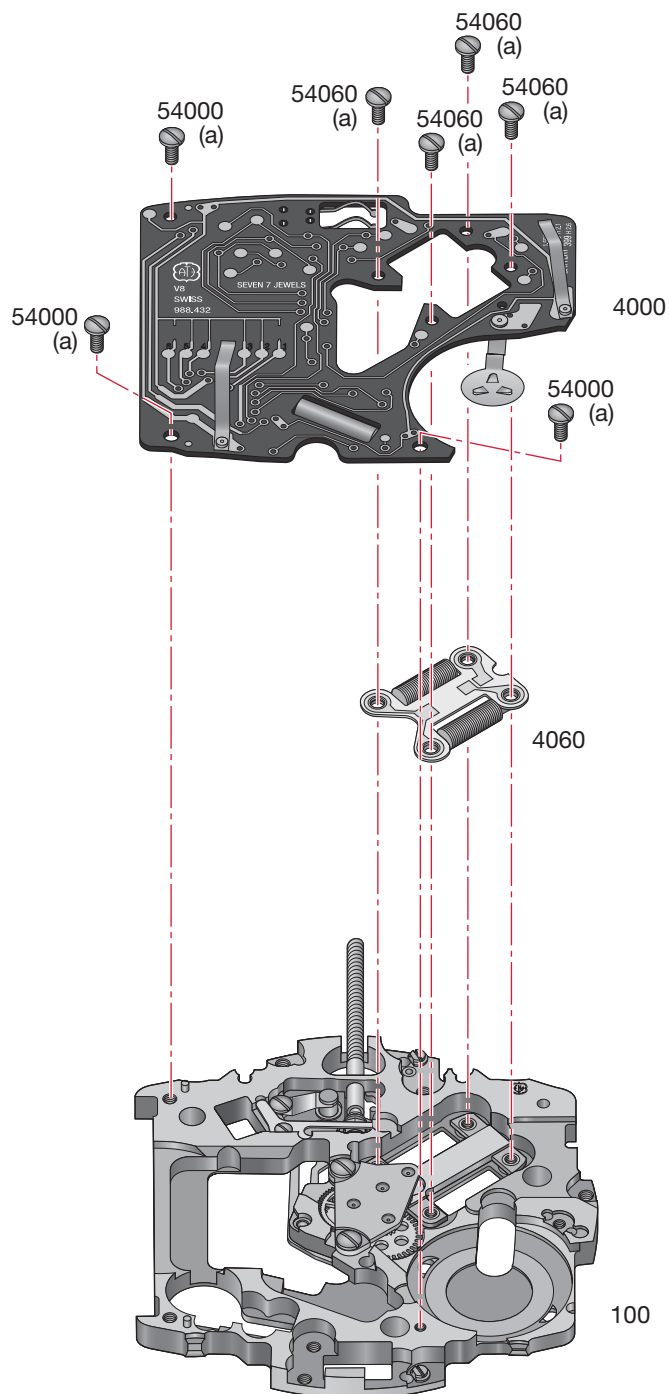

Assembling of the electronic module

(Parts listed in order of assembly)

Montaje del módulo electrónico

(Lista de fornitureas por orden de ensamblado)

Montaggio del modulo elettronico

(Elenco delle forniture in ordine di montaggio)

4060
4000

54060 (4x)
54000 (3x)

M_L Minimum torque for loosening**M_L Par mínimo para desatornillar****M_L Coppia minima per svitare**

(a) 0,7 Ncm

Order of assembly - Orden del montaje - Ordine dell'assemblaggio
 Display module - Módulo de señalamiento - Modulo di affissione

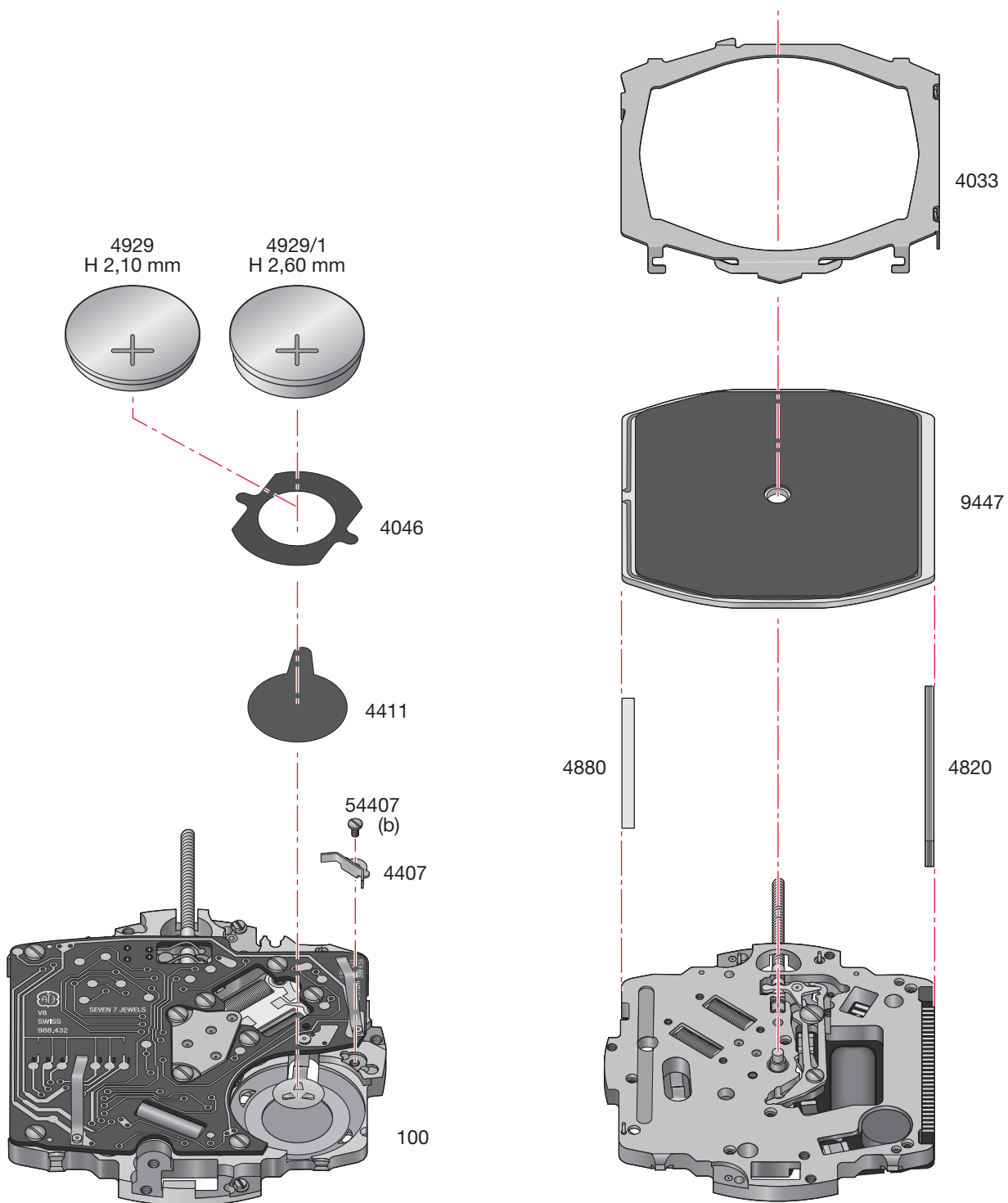

Assembling of the display module

(Parts listed in order of assembly)

Montaje del módulo de señalamiento

(Lista de forniture por orden de ensamblado)

Montaggio del modulo di affissione

(Elenco delle forniture in ordine di montaggio)

4820	4033	4411
4880	4407	4046
9447	54407 (1x)	4929

M_L Minimum torque for loosening

M_L Par mínimo para desatornillar

M_L Coppia minima per svitare

(b) 0,6 Ncm

Electrical tests - Controles eléctricos - Controlli elettrici

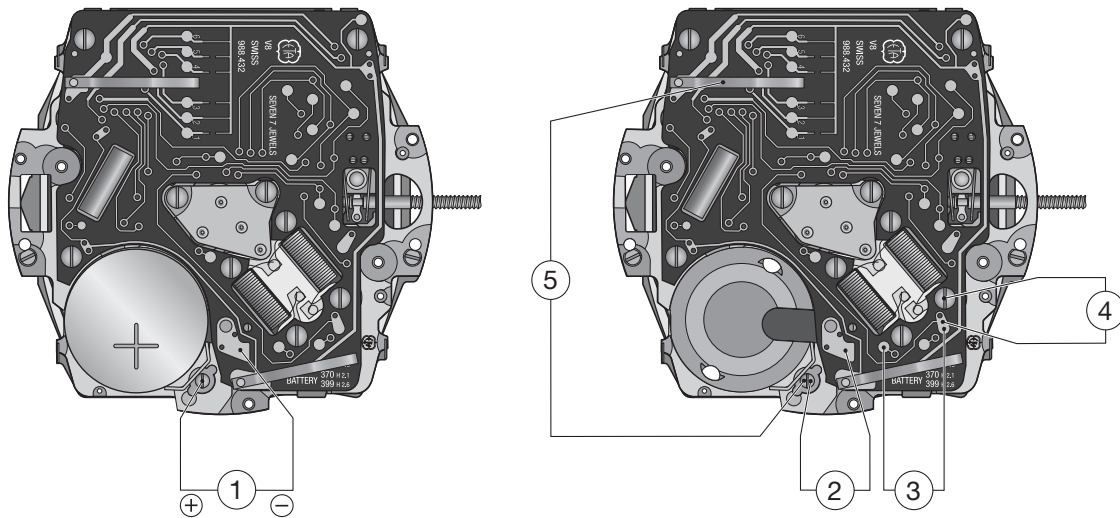

Measurements in positions 2, 3, 4 and 5 are made without battery.

Las mediciones en las posiciones 2, 3, 4 y 5 se realizan sin pila.

Le misurazioni in posizione 2, 3, 4 e 5 si effettuano senza pila.

Electrical tests - Controles eléctricos - Controlli elettrici

Position Posición Posizione	Setting of apparatus Escala de medición Scala di misura	Measurement Medición Misura	Test Control Controllo	Remarks Notas Osservazioni
1	2 V ($R_i \geq 10 \text{ k}\Omega/\text{V}$)	1,55 V	Battery voltage. Tensión de la pila. Tensione della pila.	Measurement with battery. Medición con pila. Misura con pila.
2	10 μA	$\leq 2,00 \mu\text{A}$	Consumption of movement Consumo de la máquina Consumo del movimento	Measurement without battery, with power supply unit 1.55 V. (all functions, except alarm). Medición sin pila, con alimentación exterior de 1,55 V. (todas las funciones, salvo alarma). Misura senza pila, con alimentazione esterna di 1,55 V. (tutte le funzioni, eccetto allarme).
	1 mA	$\sim 700 \mu\text{A}$	Alarm consumption piezo Consumo del despertador piezo Consumo della sveglia piezo	Measurement without battery with power supply unit 1.55 V. - Select the "Alarm" function. Press on the crown to activate the alarm and measure. Medición sin pila, con alimentación exterior de 1,55 V. - Seleccionar la función "Alarma". Presionar la corona para activar la alarma y medir. Misura senza pila, con alimentazione esterna di 1.55 V. - Selezionare la funzione "Allarme" Premere sulla corona per far scattare la suoneria, poi misurare.
	2 V	< 1,25 V The numerals blink Las cifras parpadean Le cifre lampeggiano	E.O.L. Function E.O.L. Funcionamiento E.O.L. Funzionamento	Measurement without battery, with feed voltage < 1.25 V. E.O.L. Function after about 2 minutes. Medición sin pila, con tensión de alimentación < 1,25 V. E.O.L.-Funcionamiento después de ~ 2 minutos. Misura senza pila, con tensione di alimentazione < 1,25 V. E.O.L. Funzionamento dopo ~ 2 minuti.

Position Posición Posizione	Setting of apparatus Escala de medición Scala di misura	Measurement Medición Misura	Test Control Controllo	Remarks Notas Osservazioni
3	~ 10 kΩ	2,0–2,4 kΩ	Resistance of coil (M1–M2) Continuidad de las bobinas (M1–M2) Continuità delle bobine (M1–M2)	Measurement without battery. Medición sin pila. Misura senza pila.
4	~ 100 kΩ	> 100 kΩ	Coil isolation (Alarm) Aislamiento de la bobina (Alarma) Isolazione della bobina (Allarme)	Measurement without battery. Medición sin pila. Misura senza pila.
5	~ 1 kΩ	80–200 Ω	Resistance of coil (Alarm) Continuidad de las bobinas (Alarma) Continuità delle bobine (Allarme)	Measurement without battery. Medición sin pila. Misura senza pila.
	Ohmmeter with a test voltage higher than 0.40 V unsuitable, recommended voltage 0.20 V. Ohmiómetros con tensión de medición superior a 0,40 V inapropiados, tensión recomendada 0,20 V. Ohmmetri con tensione di misura superiore a 0,40 V sono inadeguati, tensione raccomandata 0,20 V.			

*The test must be conducted at an ambient temperature of between 20°C and 25°C.
 Las pruebas deben realizarse a una temperatura ambiente comprendida entre 20°C y 25°C.
 I test devono essere effettuati a temperatura ambiente compresa tra 20°C e 25°C.*

The sequential test mode





Fit the battery with the crown pressed down. Then release the crown to enter test mode. Each time you press the crown, the test number rises by one. Each time you turn the crown, the function rises by one. As soon as the crown is pressed, "Test" and test number are displayed. When the crown is released, the test starts and the test mode or the expected test result is displayed (i.e. event or odd segments, LCD off...). Depressing the crown for more than 4 s will reinitialize the test (TEST 00).









Modo de prueba secuencial





Montar la pila con la corona presionada. Al soltar la corona, se entra en modo de prueba. Cada presión de corona incrementa el número de prueba, la rotación incrementa la función. Apenas se presiona la corona, se visualiza "Test" así como el número de prueba. Al soltarse la corona, comienza el test y el modo Test 0 los resultados de la prueba esperados se visualizan (ej. segmento pare o impares, LCD apagado...). Si se presiona la corona durante más de 4 s, la prueba se reinicializa (Test 00).

Modalità di test sequenziale

Posizionare la pila con la corona premuta. Quando la corona viene rilasciata, entrate nella modalità test. Ogni volta che viene esercitata una pressione sulla corona, il numero di test aumenta, mentre ogni rotazione aumenta la funzione. Fino a quando la corona rimane premuta, il display indica "Test" anziché il numero del test. Non appena la corona viene rilasciata, il test si avvia e il display indica la modalità Test oppure ciò che è imposto dal test (per es.: segmenti pari o dispari, LCD spento...). Premendo la corona per più di 4 s, il test viene nuovamente inizializzato (TEST 00).

Test mode Modo test Modo test	LCD display Indicación LCD Affissione LCD	Test description Descripción del test Descrizione del test	
Identification Identificación Identificazione	TEST 00	Display of the electronic circuit used Visualización del circuito electrónico utilizado Visualizzazione del circuito elettronico utilizzato	
Test 0.0:	0430Fb	An identification code (software version) is displayed on the LCD En la pantalla se visualiza un código de identificación (versión software) Un codice di identificazione (versione software) è indicato sul LCD	
Alarm test Test alarma Test allarme	TEST 10	Test of the 3 alarm frequencies: audible with piezo only Control de las 3 frecuencias de alarma: audible sólo con piezo Controllo delle 3 frequenze di allarme: udibile solo con piezo	
Test 1.0:	10	Alarm frequency 2.7 kHz Frecuencia de alarma 2,7 kHz Frequenza di allarme 2.7 kHz	
Test 1.1:	11	Alarm frequency 2.0 kHz Frecuencia de alarma 2,0 kHz Frequenza di allarme 2.0 kHz	
Test 1.2:	12	Alarm frequency 1.3 kHz Frecuencia de alarma 1,3 kHz Frequenza di allarme 1.3 kHz	
LCD test Test LCD Test LCD	TEST 20	Test of the LCD display Control de la indicación LCD Controllo della visualizzazione LCD	

Test mode Modo test Modo test	LCD display Indicación LCD Affisione LCD	Test description Descripción del test Descrizione del test	
Test 2.0:	Even segments Segmentos pares Segmenti pari	Only the even segments are switched on. Sólo los segmentos pares están activados. Solo i segmenti pari sono attivati.	
Test 2.1:	Odd segments Segmentos impares Segmenti dispari	Only the odd segments are switched on. Sólo los segmentos impares están activados. Solo i segmenti dispari sono attivati.	
Test mode Modo test Modo test	LCD display Indicación LCD Affisione LCD	Test description Descripción del test Descrizione del test	
Motor test Test motor Test motore	TEST 30	Motor function test Control de las funciones motor Controllo delle funzioni motore	
Test 3.0:	30	120 steps forward / 120 pasos hacia adelante / 120 passi in avanti	
Test 3.1:	31	120 steps backwards / 120 pasos hacia atrás / 120 passi indietro	
Test 3.2:	32	1 step with and 1 step without inhibition, alternatively 1 paso con y 1 paso sin inhibición, alternadamente 1 passo con e 1 passo senza inibizione, alternativamente	
Test 3.3:	33	Steps forward (32 Hz) / Pasos hacia adelante (32 Hz) / Passi in avanti (32 Hz)	
Test 3.4:	34	Steps backwards (32 Hz) / Pasos hacia atrás (32 Hz) / Passi indietro (32 Hz)	
Test mode Modo test Modo test	LCD display Indicación LCD Affisione LCD	Test description Descripción del test Descrizione del test	
EOL test Test EOL Test EOL	TEST 40	Test of the battery end of life Control de fin de vida de la pila Controllo di fine vita della pila	
Test 4.0:	100	Supply = 1.55 V -> Alarm (2.7 kHz), word '100' displayed on LCD. Alimentación = 1,55 V -> Alarma (2,7 kHz), '100' visualizado en pantalla. Alimentazione = 1.55 V -> Allarme (2.7 kHz), '100' visualizzato sul LCD.	
	EOL	Supply < 1.25 V -> No alarm, word 'EOL' displayed on LCD. Alimentación < 1,25 V -> Sin alarma, 'EOL' visualizado en pantalla. Alimentazione < 1.25 V -> Senza allarme, 'EOL' visualizzato sul LCD.	
Test mode Modo test Modo test	LCD display Indicación LCD Affisione LCD	Test description Descripción del test Descrizione del test	
Consumption test Test de consumo Test di consumo	TEST 50	Measure of Micro-Controller consumption Medición del consumo del Micro-Controller Misura del consumo del Micro-Controller	
Test 5.0:	No display No se visualiza Senza affissione	In HALT mode, all LCD segments are 'OFF'. En modo HALT, todos los segmentos LCD están apagados. In modo HALT, tutti i segmenti LCD sono spenti.	
Test 5.1:	No display No se visualiza Senza affissione	In STOP mode, all LCD segments and LCD driver are switched off. En modo STOP, todos los segmentos LCD y el piloto LCD están desconectados. In modo STOP, tutti i segmenti LCD e il comando LCD sono disinnestati.	
	TEST 60		
Test 6.0:	All LCD segments are visible Todos los segmentos LCD están visibles Tutti i segmenti LCD sono visibili	In RUNNING mode, all LCD segments are visible. En modo RUNNING, todos los segmentos LCD están visibles. In modo RUNNING, tutti i segmenti LCD sono visibili.	
Test mode Modo test Modo test	LCD display Indicación LCD Affisione LCD	Test description Descripción del test Descrizione del test	
Motor outputs Salidas motor Uscite motore	TEST 70	Test of the motor outputs on high impedance Control de las salidas motor en alta impedancia Controllo delle uscite motore in alta impedenza	
Test 7.0:	70	When the motor outputs are switched on high impedance, the transistors are open. This mode allows to control motor steps with an external generator without interfering the IC. Cuando las salidas motor están en alta impedancia, los transistores están abiertos. Este modo permite controlar los pasos del motor con un generador externo, sin interferencia con el IC. Quando le uscite motore sono in alta impedenza, i transistor sono aperti. Questo modo permette di comandare dei passi al motore con il generatore esterno, senza interferire con l'IC.	

Test mode Modo test Modo test	LCD display Indicación LCD Affissione LCD	Test description Descripción del test Descrizione del test	
Contacts and direction Contactos y dirección Contatti e direzione	TEST 80	Electronic test of the crown electric contacts Control electrónico de los contactos eléctricos de la corona Controllo elettronico dei contatti elettrici della corona	
Test 8.0:	See text Ver texto Vedre testo	The contacts A and B are the crown contacts. According to their open or closed status, they allow the detection of the direction and speed of the crown rotation. Los contactos A y B son los contactos de la corona. Según su estado, abiertos o cerrados, éstos permiten detectar el sentido y la velocidad de rotación de la corona. I contatti A e B sono i contatti della corona. Secondo il loro stato, aperto oppure chiuso, permettono di rilevare il senso e la velocità della rotazione della corona.	
	See text Ver texto Vedre testo	A and B are displayed on the first two digits. The status is 1 or 0. A y B se visualizan con los dos primeros dígitos. El estado es de 1 ó 0. A e B sono indicati sulle due prime cifre. Lo stato è di 1 o 0.	
	See text Ver texto Vedre testo	Direction is displayed on the fourth digit. Forwards is 0, backwards 1. La dirección se visualiza con el cuarto dígito. Adelante es 0, atrás es 1. La direzione è indicata sulla quarta cifra. In avanti è 0, indietro è 1.	
	See text Ver texto Vedre testo	Counter status is displayed on the sixth digit. The value is between 0 and 7. When 7 is reached, the counter stays on this value until the direction changes. When this occurs, the counter starts again from 0. El estado del contador se visualiza con el sexto dígito. El valor está comprendido entre 0 y 7. Al llegar a 7, el contador permanece en este valor hasta que la dirección cambia. En este caso, el contador vuelve a empezar desde 0. Lo stato del contatore è indicato sulla sesta cifra. Il valore è compreso tra 0 e 7. Quando 7 è raggiunto, il contatore resta con questo valore finché la direzione cambia. In questo caso, il contatore riparte da 0.	
Test mode Modo test Modo test	LCD display Indicación LCD Affissione LCD	Test description Descripción del test Descrizione del test	
End of test Fin del test Fine del test	TEST 90		
Test 9.0:	All LCD segments are visible. Todos los segmentos LCD están visibles Tutti i segmenti LCD sono visibili	To quit the test mode, turn the crown. The watch is running. Para salir del modo test, gire la corona. El reloj funciona. Per uscire dal modo test, girare la corona. L'orologio funziona.	

Recommendations for fitting the hands

Fitting the hands

The use of a movement holder is indispensable for supporting the lower pivot of the centre wheel. The movement holder No. 041270 is recommended.

It can be ordered from:

ETA SA Manufacture Horlogère Suisse
Customer Support
Bahnhofstrasse 9
2540 Grenchen
Switzerland
Phone +41 32 655 27 77
Fax +41 32 655 84 30
customer-support@eta.ch
www.eta.ch

The hands must be fitted on a running movement i.e. with the battery in place.

1. Fit the battery with the crown in neutral position. The numerical display passes automatically to the "All on" mode.

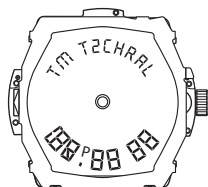

2. Turn the crown.
The display passes to the "Local time" mode (see Instructions for use). All the numerals indicate zero.

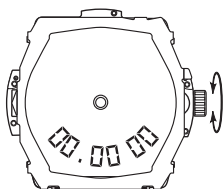

The watch starts functioning.

3. Fit the hour hand by centering it precisely at the 12 o'clock mark. Slight displacement of the hand can be, if needed, corrected by turning the crown in the pulled-out position.
4. Pull the crown out and then push it back in.
The numerical display indicates flashing seconds.

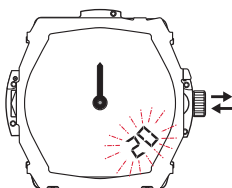

Removal of hands

Only with Bergeon tool ref. 30.671-7.

5. Press the crown in, while the numerals flash. The seconds are brought back to zero.

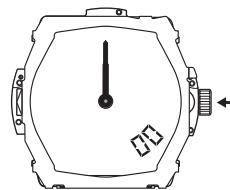

6. Set the minute hand precisely on the 12 o'clock mark.
7. Synchronising the analog and the numerical display.

Proceed as follows:

- Select the neutral numerical display of the cell (see: Instructions for use), without any indication, by turning the crown.
- Pull out crown. The R symbol appears on the upper section of the dial.
- Turn the crown forwards or backwards till the hands indicate precisely the same time as shown by the numerical display.
- Push the crown back in.

8. Setting the time

Proceed as follows:

- Bring back the numerical display to the "Local time" (see Instructions for use), by turning the crown.
- Pull out crown. The T symbol appears on the upper section of the dial. The numerals indicating hours and minutes start to flash.
- Set the watch to time by turning the crown forwards or backwards (turn the crown quickly to adjust the time by one full hour, slowly to correct the minutes).
- Push the crown back in.

N.B.:

In case the battery is fitted in advance, then the process can be interrupted without any problem even for a long time, if so desired, between the point 2 and the point 3. The hands will still be fitted at 12 o'clock and the time lapse between the two displays will be overcome with the synchronisation operation as described in point 7.

Recomendaciones para la colocación de las agujas

Colocación de las agujas

El empleo de un portamáquinas es indispensable para sujetar el pivote inferior del piñón de centro. Se recomienda el portamáquinas No. 041270.

Este portamáquinas puede ser pedido a:

ETA SA Manufacture Horlogère Suisse

Customer Support

Bahnhofstrasse 9

2540 Grenchen

Switzerland

Phone +41 32 655 27 77

Fax +41 32 655 84 30

customer-support@eta.ch

www.eta.ch

La colocación de las agujas debe hacerse necesariamente sobre máquinas con pila y en marcha.

1. Colocar la pila con la corona en posición neutra. La célula de indicación pasa al modo „all on“ (todos los segmentos de la indicación son visibles).

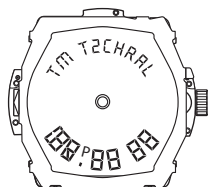

2. Girar la corona. La célula de indicación pasa al modo „Hora local“ (véase el modo de empleo), con todas las cifras en cero.

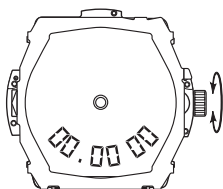

El reloj empieza a funcionar.

3. Colocar la aguja de las horas, bien centrada sobre la marca de referencia a las 12 horas, el centraje puede eventualmente ser corregido girando la corona en posición scada.
4. Sacar la corona y empujarla de nuevo. Las cifras que indican segundos empiezan a parpadear.

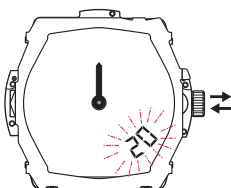

Desmontaje de las agujas

Sacar las agujas únicamente con una herramienta Bergeon ref. 30.671-7.

5. Mientras las cifras parpadean, presionar la corona a fondo. Las cifras de los segundos se ponen en cero.

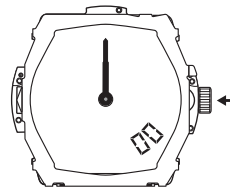

6. Colocar la aguja de minutos bien centrada sobre la marca de referencia a las 12 horas.
7. Sincronizar las dos indicaciones, analógica (agujas) y numérica.

Para éso:

- Seleccionar la indicación neutra de la célula (véase el modo de empleo), sin ninguna indicación numérica, girando la corona.
- Tirar de la corona. El símbolo R aparece en la esfera superior.
- Girar la corona, hacia adelante o hacia atrás, hasta que las agujas indiquen exactamente la misma hora que la que está indicada por la célula de indicación.
- Empujar de nuevo la corona.

8. Efectuar la puesta en hora

Para éso:

- Volver a la indicación de la hora local, girando la corona (véase el modo de empleo).
- Tirar de la corona. El símbolo T aparece en la esfera superior, las cifras que indican las horas y los minutos empiezan a parpadear.
- Hacer la puesta en hora girando la corona hacia adelante o hacia atrás (una rotación rápida permite avanzar o retroceder las agujas una hora entera, una rotación lenta corrige los minutos).
- Empujar de nuevo la corona.

NOTA:

Si la pila está ya colocada, es posible interrumpir el proceso todo el tiempo que desee, entre las operaciones 2 y 3. Las agujas quedarán siempre colocadas sobre las 12 horas y la diferencia entre las dos indicaciones se recuperará durante la operación 7 de sincronización.

Raccomandazioni per la posa delle lancette

Posa delle lancette

L'uso di un porta-pezzo è indispensabile per correggere il perno inferiore del pignone di centro. Si consiglia il portapezzo No. 041270.

Può essere ottenuto presso:

ETA SA Manufacture Horlogère Suisse

Customer Support

Bahnhofstrasse 9

2540 Grenchen

Switzerland

Phone +41 32 655 27 77

Fax +41 32 655 84 30

customer-support@eta.ch

www.eta.ch

È d'obbligo che la posa delle lancette deve essere fatta su un movimento in marcia con pila.

1. Collocare la pila, essendo la corona in posizione neutra. La cellula di affissione passa al modo „All on“ (vale a dire che tutti i segmenti di affissione sono visibili).

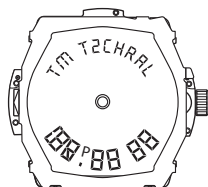

2. Girare la corona. La cellula di affissione passa al modo „Ora locale“ (vedere le istruzioni per l'uso) tutte le cifre messe a zero.

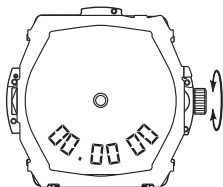

L'orologio incomincia a funzionare.

3. Posare la lancetta delle ore centrata bene sul riferimento alle ore 12, la centratura può eventualmente essere corretta girando la corona in posizione tirata.
4. Tirare poi spingere la corona. Le cifre che segnano i secondi cominciano a lampeggiare.

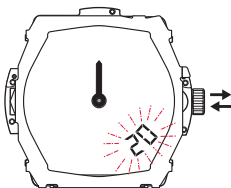

Rimozione delle lancette

Togliere le lancette unicamente con l'attrezzo Bergeon ref. 30.671-7.

5. Mentre le cifre lampeggiano, premere a fondo la corona. Le cifre che segnano i secondi sono rimesse a zero.

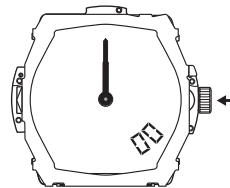

6. Posare la lancetta dei minuti centrata bene sul riferimento alle ore 12.
7. Sincronizzare le due affissioni analogiche (lancette) e numeriche.

A tale scopo:

- Selezionare l'affissione neutra della cellula (vedere le istruzioni per l'uso), senza nessuna indicazione numerica, girando la corona.
- Tirare la corona. Il simbolo R appare nel quadrante superiore.
- Girare la corona in avanti o indietro fino quando le lancette segnano esattamente la medesima ora di quella indicata dalla cellula di affissione.
- Spingere la corona.

8. Effettuare la messa all'ora

A tale scopo:

- Tornare all'affissione dell'ora locale girando la corona (vedere le istruzioni per l'uso).
- Tirare la corona. Il simbolo T appare nel quadrante superiore, le cifre che segnano le ore ed i minuti cominciano a lampeggiare.
- Mettere l'orologio all'ora girando la corona in avanti o all'indietro (una rapida rotazione permette di spostare in avanti o indietro le lancette di un'ora intera, una lenta rotazione corregge i minuti).
- Spingere la corona.

NOTA:

Nei casi dove si desidererebbe collocare la pila in anticipo, si può senz'altro interrompere il processo quanto necessario tra le operazioni 2 e 3. Le lancette saranno sempre posate sulle ore 12; la differenza tra le due affissioni essendo recuperata durante l'operazione di sincronizzazione No. 7.

Ajustement aiguille des heures
Stundenzeigerpassung
Hour hand fitting

Ajustement aiguille des minutes
Minutenzeigerpassung
Minute hand fitting

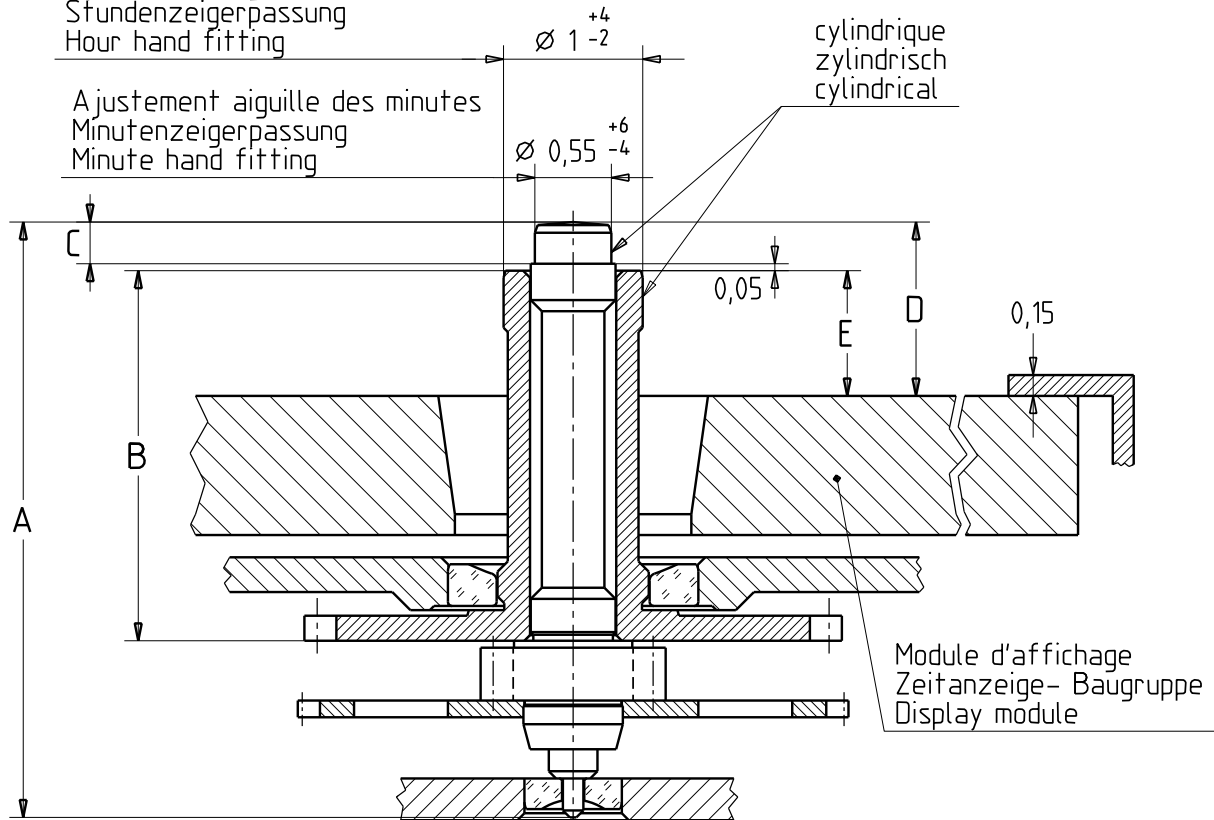

Aiguillage Zeigerwerk- höhe Hand fitting height	Longueur / Länge / Length			Dépassement Höhe über Zeitanzeige-Baugruppe Height over display module		
	A	B	C	D	E	
réduit / niedrig / reduced	3,58	2,01	0,25	0,55	0,25	
1	3,98	2,41	0,25	0,95	0,65	
2	4,28	2,66	0,30	1,25	0,90	
Aiguilles Zeiger Hands	Aiguille des heures Stundenzeiger Hour hand		Aiguille des minutes Minutenzeiger Minute hand			
Masse / Masse / Mass	max.	mg	—	10		
Balourd / Unwucht / Unbalance	max.	µNm	—	0,35		
Inertie / Trägheit / Inertia	max.	gmm ²	—			
Kaliber / Calibre / Caliber				Masstab Echelle Scale		EUCLID321B
988432				--	Masse in mm Dimensions en mm Dimensions in mm	Tol. 1/1000 mm
AIGUILLAGES ZEIGERWERKHÖHEN HAND FITTING HEIGHTS				Version	Revision Révision	Blatt Feuille Sheet
				Z0028798	00	00 01
Ersatz für En remplacement de Remplacement for					Klass. Class. ZVACC	
Aenderung Modification			Geprüft Contrôlé Controlled		Freigegeben Libéré Released	
			ETA SA Manufacture Horlogère Suisse CH-2540 Grenchen UNE SOCIÉTÉ DU		KUN	
			07.11.2000 HAM		28.11.2000 RYS	
					28.11.2000 FEU	

We reserve all rights for this document. It is meant for the recipient only and it may not be copied, printed or given to a third person without our written permission. Quedan reservados todos los derechos relacionados con este documento, que está dirigido únicamente al destinatario. Queda por lo tanto prohibida su copia, impresión a terceros sin nuestra autorización por escrito. Ogni diritto su questo documento è riservato. Il documento è indirizzato esclusivamente al destinatario e non può essere copiato, stampato o ceduto a terzi senza un'autorizzazione scritta.

This page has deliberately been left blank in case of A3 format printing.

Esta página se han dejado en blanco a propósito en caso de imprimirla en formato A3.

Questa pagina è lasciata intenzionalmente bianca in caso di stampa formato A3.

This page has deliberately been left blank in case of A3 format printing.

Esta página se han dejado en blanco a propósito en caso de imprimirla en formato A3.

Questa pagina è lasciata intenzionalmente bianca in caso di stampa formato A3.

Modifications compared with previous document versions**Modificaciones comparadas con las versiones anteriores del documento****Modifiche comparate con le versioni precedenti del documento**

Version Versión Version	Date Fecha Data	Modification	Modificación	Modifica	Page Página Pagina
02	13.03.2012	New address	Nueva dirección	Nuovo indirizzo	1, 4, 18-20
		New layout	Nuevo layout	Nuova layout	1-24
01	08.09.2009	Remove parts No 166, 5101, 5102 and 5166	Eliminar piezas No. 166, 5101, 5102 y 5166	Soppressione degli pezzi No 166, 5101, 5102 e 5166	2, 3, 5
		Minimum torque for loosening	Par mínimo para desatornillar	Coppia Minima per svitare	4-7
		New layout	Nuevo layout	Nuova layout	1-16
00	26.05.2009	Basic version	Versión de base	Versione di base	--

All modifications reserved.

Salvo modificación.

Con riserva di ogni eventuale modifica.

This document can be found on the Support Center Portal (SCP):**www.eta.ch**

- Support Center
- Support Center Portal
- Technical Documents

Este documento se encuentran en el Support Center Portal (SCP):**www.eta.ch**

- Support Center
- Support Center Portal
- Technical Documents

Il presente documento si trovano sul Support Center Portal (SCP):**www.eta.ch**

- Support Center
- Support Center Portal
- Technical Documents



ETA^{SA}
MANUFACTURE HORLOGÈRE SUISSE
DEPUIS 1793

SC PRODUCT COMMUNICATION

Bahnhofstrasse 9
2540 Grenchen
Switzerland

Phone +41 (0)32 655 71 11
Fax +41 (0)32 655 71 74

contact@eta.ch
www.eta.ch